

HCH

Standard 3-Jaw Open-Center Chuck (110mm - 304mm)



■ Standard 3-jaw wedge-style open-center chuck

HYDRAULIC CHUCK

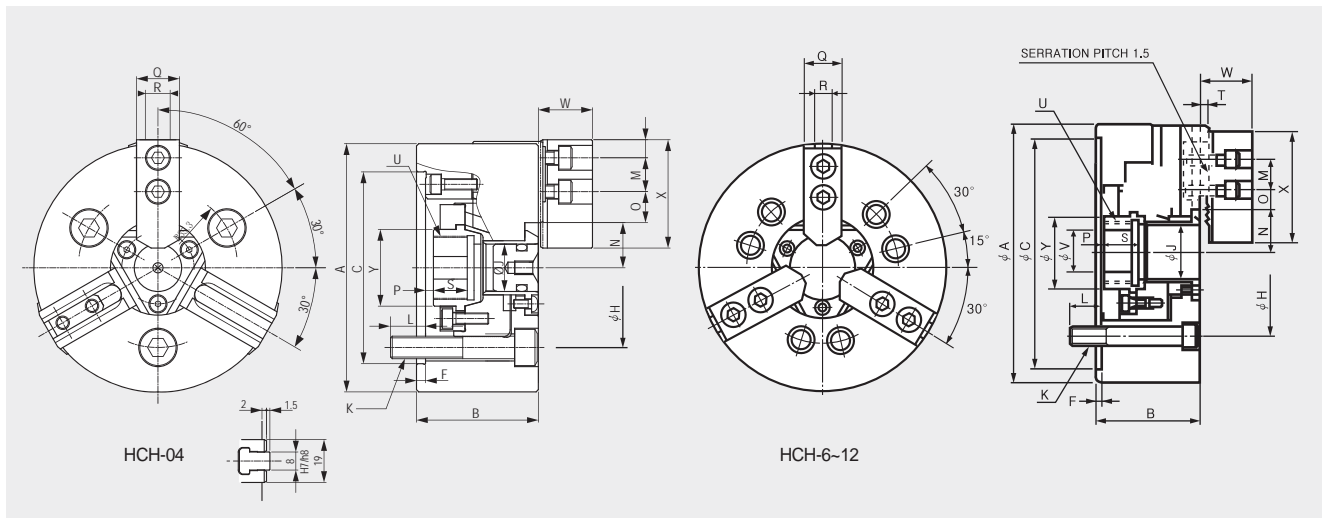

Dimensions

	A	B	C(H6)	F	H	J	K	L	M	Nmax.	Nmin.	Omax.	Omin.	Pmax.	Pmin.	Q	R	S	T	Umax.	V	W	X	Y
HCH-04	110	54	85	4	70.6	21	3-M10	15.5	15	20.0	17.9	14.25	6.75	3.5	-3	19	8	15	2	M28x1.5	13	24	48	34
HCH-06	165	83	140	5	104.8	33	6-M10	14	20	27.5	24.75	25.75	10.75	10	-2	31	12	24	4	M42x1.5	16	35	72	48.8
HCH-08	210	91	170	5	133.4	46	6-M12	20	25	35.7	32	31.25	13.25	3	-13	35	14	30	5	M55x2.0	30	42	95	61
HCH-10	254	100	220	5	171.4	65	6-M16	23	30	50	45.6	32.25	12.75	-25	-6	40	16	35	5	M75x2.0	45	46	110	84.5
HCH-12	304	110	220	6	171.4	78	6-M16	23	30	58	52.7	48.75	12.75	8	-15	49	18	38	5	M88x2.0	50	53.5	129	96

* Blank and machined draw-nuts are available.

* "U" is Max. Draw nut size.

Specifications

	Thru Hole Diameter.(mm)	Grip Dia. (mm)		Jaw STROKE Diameter. (mm)	PLUNGER STROKE (mm)	Permissible Input Force KN(kgf)	Max. Static Gripping Force KN(kgf)	Max. r.p.m min ⁻¹ (r.p.m)	weight kgf	GD ² N·m ² (kgf·m ²)	Operating Cylinder	Max. Hydraulic Pressure MPa(kgf/cm ²)	Operating HARD JAW	KITAGAWA Model
		Max.	Min.											
HCH-04	21	110	5	4.2	6.5	8(800)	13(1350)	5500	3.7	0.2 (0.024)	HYH-0933	2.2 (22.4)	HB04A1	B-04
HCH-06	33	165	12	5.5	12	20(2039)	51(5200)	5000	14	2.00 (0.20)	SH-13046	2.2 (22.4)	HB06A1	B-06
HCH-08	46	210	13	7.4	16	31(3161)	78(7954)	4000	25	5.59 (0.57)	SH-15052 (SYH-1552)	2.2 (22.4)	HB08A1	B-08
HCH-10	65	254	25	8.8	19	38(3875)	99(10095)	3500	38	12.94 (1.32)	SH-18077 (SYH-1877)	2.3 (23.5)	HB10A1	B-10
HCH-12	78	304	19	10.6	23	49(4997)	129(13150)	3000	63	29.71 (3.03)	SH-19082	2.3 (23.5)	HB12B1	B-12

* Maximum turning speed is based on actual measurements.

* Specifications are subject to change without notice.

HCH

Standard 3-Jaw Open-Center Chuck (381mm-800mm)



■ Standard 3-jaw wedge-style open-center chuck

HYDRAULIC CHUCK

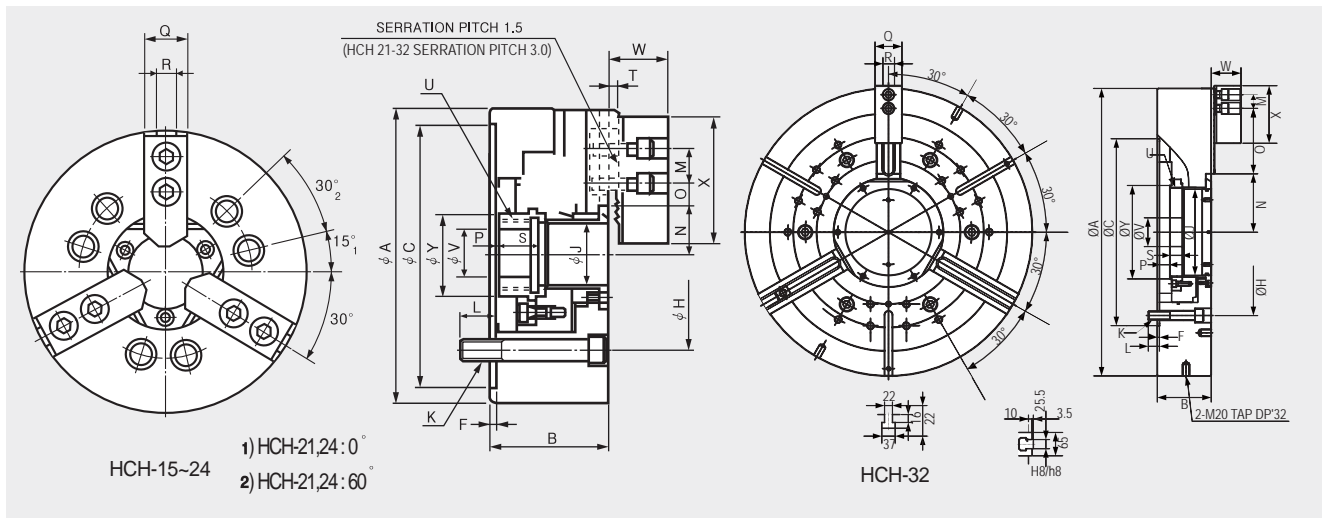

Dimensions

	A	B	C(H6)	F	H	J	K	L	M	Nmax.	Nmin.	Omax.	Omin.	Pmax.	Pmin.	Q	R	S	T	Umax.	V	W	X	Y
HCH-15	381	133	300	6	235.0	117.5	6-M20	30	43	82	76.7	43.75	18.25	11	-12	62	22	39	5	M130x2.0	60	70	165	139
HCH-18	450	133	380	6	235.0	117.5	6-M20	30	43	82	76.7	78.25	18.25	11	-12	62	22	39	5	M130x2.0	60	70	165	139
HCH-21	530	140	380	6	330.2	140	6-M22	31	60	98.5	93.2	87.5	21.5	11	-12	65	25	39	5	M155x3.0	80	72	180	170
HCH-21N	530	140	380	6	330.2	140	6-M24	31	60	98.5	93.2	87.5	21.5	11	-12	65	25	39	5	M155x3.0	80	72	180	170
HCH-24	610	149	380	6	330.2	165	6-M22	32	60	108	102.7	117.5	21.5	20	-3	65	25	40	5	M175x3.0	80	72	180	187
HCH-24N	610	149	380	6	330.2	165	6-M24	32	60	108	102.7	117.5	21.5	20	-3	65	25	40	5	M175x3.0	80	72	180	187
HCH-32	800	150	520	6	463.6	240	6-M24	31	38	162.6	153.6	182	20	29	-5	75	25.5	34.5	10	M250x3.0	80	83	160	260

* Blank and machined draw-nuts are available.

** "U" is Max. Draw nut size.

Specifications

	Thru Hole Diameter.(mm)	Grip Dia. (mm)		Jaw STROKE Diameter. (mm)	PLUNGER STROKE (mm)	Permissible Input Force KN(kgf)	Max. Static Gripping Force KN(kgf)	Max. r.p.m min ⁻¹ (r.p.m)	weight kgf	GD ² N·m ² (kgf·m ²)	Operating Cylinder	Max. Hydraulic Pressure MPa(kgf/cm ²)	Operating HARD JAW	KITAGAWA Model
		Max.	Min.											
HCH-15	117.5	381	30	10.6	23	71(7240)	180(18355)	2500	120	89.14 (9.09)	SH-25011	2.3 (23.5)	HB15A1	B-15
HCH-18	117.5	450	30	10.6	23	71(7240)	180(18355)	2000	164	174.6 (17.8)	SH-25011	2.3 (23.5)	HB15A1	B-18
HCH-21	140	530	87	10.6	23	90(9177)	234(23861)	1700	235	351.1(35.8)	SH-25011	3.0(30.6)	HB18B2	B-21
HCH-21N	140	530	87	10.6	23	90(9177)	234(23861)	1700	235	351.1(35.8)	SH-25011	3.0(30.6)	HB18B2	B-21
HCH-24	165	610	110	10.6	23	90(9177)	234(23861)	1400	293	651.2(66.4)	SYHL-2816	3.0(30.6)	HB18B2	B-24
HCH-24N	165	610	110	10.6	23	90(9177)	234(23861)	1400	293	651.2(66.4)	SYHL-2816	3.0(30.6)	HB18B2	B-24
HCH-32	240	800	240	18	34	100(10193)	240(24464)	1200	530	598.4(61)	SYHL-2816	3.2(33.6)	HB32B2	-

* Maximum turning speed is based on actual measurements.

** Specifications are subject to change without notice.